

Ramps are intended for specific applications and it is imperative the ramp that you have purchased is not used for any other application than its intention. Please carefully read and comply with the instructions on how to use loading ramps.

Instructions are as follows:

1. The bolt(s) must be inserted and hand-tightened through the barrel hinge(s).
2. Park the vehicle or trailer on flat, firm ground.
3. Place the ramp on the tailgate or trailer to accommodate the wheelbase of the loading vehicle.
4. Make sure the plate or fingers of the ramp are securely in place.
5. Install and secure the safety strap(s). An illustration on how to secure the safety strap(s) is as follows:

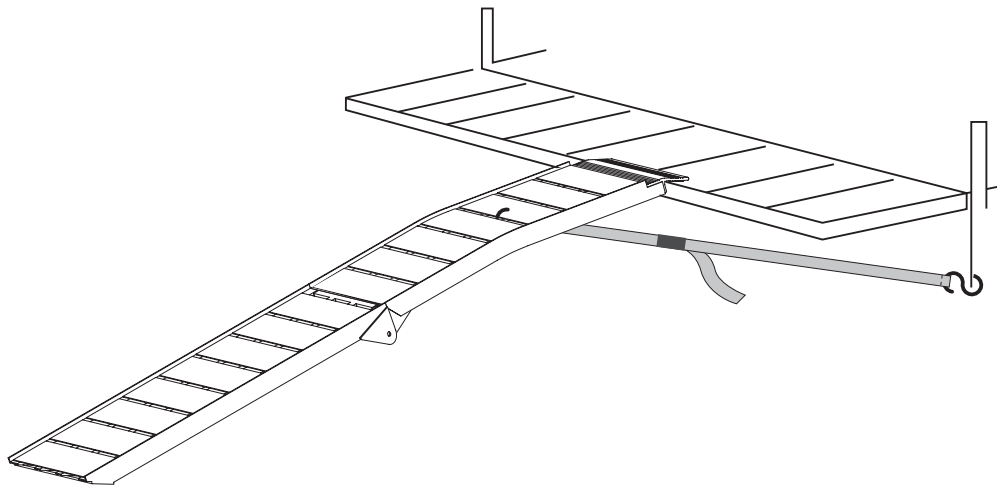

6. Slowly ride the machine up the ramp making sure the tires are centered on the ramp at all times.
7. Acceleration must be slow, controlled and constant. The operator must remain in control of the machinery at all times during loading and unloading.
8. Use the brake as necessary to control your speed while unloading. Sudden or erratic braking or accelerating will cause the ramp to pull away from the tailgate or trailer.

Warning! - Never exceed the maximum load capacity of the ramp(s). Use at your own risk.

Allgemeine Hinweise

Bitte, haben Sie Verständnis dafür, dass AceBikes keine Haftung für Folgeschäden übernimmt, die durch eine unsachgemäße beziehungsweise mangelhafte Montage entstehen.

General advice

Please understand, that Acebikes cannot be held responsible for any consequential loss or damage due to an improper assembly or use of the product.

Informations générales

Veillez comprendre que AceBikes ne peut être tenu pour responsable des dommages consécutifs à un montage ou une utilisation incorrecte.

